

X130

**RIDUTTORI A
VITE SENZA FINE**

WORMGEARBOXES

SCHNECKENGETRIEBE

Caratteristiche

- I riduttori a vite senza fine della serie X130 sono disponibili nelle versioni alberata XA e con predisposizione per attacco motore XF-XC.
- La versione XF (campana + giunto) è caratterizzata da una più ampia versatilità ai diversi tipi di applicazioni.
- La carcassa monoblocco è in ghisa e verniciata BLU RAL5010.
- La vite senza fine è in acciaio legato cementato-temprato ed è rettificata.
- La corona ha il mozzo in ghisa con riporto di fusione dell'anello in bronzo.
- Viene fornito l'albero uscita cavo di serie ed esiste un'ampia disponibilità di accessori: seconda entrata, cuscinetti conici sulla corona, flangia uscita, albero lento con 1 o 2 sporgenze.

Characteristics

- The X130 Series worm gearboxes are available in the following versions : XA with shaft, XF – XC suitable for motor mounting assembling.
- The XF version (bell – coupling) is extremely versatile for utilization in various applications.
- The enbloc housing is built in cast iron and painted BLUE RAL 5010.
- The worm shaft is ground and is made of hardened - casehardened compound steel.
- The worm wheel features a cast iron hub with bronze casting.
- The hollow output shaft is supplied as standard. A broad range of accessories is available: second input, tapered roller bearings on the worm wheel, output flange, single or double extended output shaft.

Merkmale

- Die Schneckengetriebe der Serie X130 sind in den Versionen XA mit Welle und XF – XC mit Motoranschluss lieferbar.
- Die Serie XF (Glocke + Kupplung) bietet verschiedene Versionen an, die zur vielseitigen Anwendbarkeit in vielerlei Applikationen dient.
- Das Block Gehäuse ist aus Gusseisen und mit BLAU RAL 5010 lackiert.
- Die Schneckenwelle ist aus legierten gehärteten Einsatzstahl und ist geschliffen.
- Das Schneckenrad verfügt über eine Nabe aus Gusseisen mit Schmelzeinsatz aus Bronze.
- Die Hohlwelle gehört zur Serienausstattung und folgendes Zubehör erhältlich ist: zweiter Antrieb, Kegellager auf Schneckenrad, Abtriebsflansch, Standard oder doppelseitige Abtriebswelle.

Designazione

Designation

Bezeichnung

Riduttore Gearbox Getriebe	Tipo entrata Input Type Antriebsart	Grandezza Size Größe	Rapporto riduzione Ratio Untersetzung	Predispos. att. mot. Motor coupling Motoranschluss	Posizione di mont. Mounting position Einbaulage	Versione Version Version	Forma costruttiva Execution Bauform	Seconda entrata Additional Input Zusatzantrieb	Albero uscita Output shaft Abtriebswelle	Braccio di reazione Torque arm Drehmomentstütze
X	A	130	10/1	P.A.M.	B3	F1S	a	SeA	H	BR
X	A	130 (X-H)		71	B3	P		SeA	H	BR
H	C			80	B6	F..D			SD	
XX	F	63/130 (XX-KX)		90	B7	F..S			SS	
KX				100	B8	F..2			DD	
				112	V5					
				132	V6					

The diagram illustrates the physical appearance of various gearbox variants. It shows three vertical columns of gearboxes. The first column contains variants X, H, and XX. The second column contains variants A, C, and F. The third column contains variants P, F..D, F..S, and F..2. Below these are variants SeA, H, SD, SS, and DD. To the right of these is the BR torque arm. Each variant is accompanied by a small technical drawing showing its specific configuration.

	$n_1 = 1400$		XC - XF										XA						
	i_n	n_2 [min ⁻¹]	T_2 [Nm]	P_1 [kW]	FS'	Input -IEC										T_{2M} [Nm]	P [kW]	Rd	P_{t0}
						XC					XF								
						B5/B14		B5			B14								
X130	7.5	187	418	9.2	1.8	132	112 100	—	132	112 100	90	—	736	16.2	0.89	6.0			
	10	140	552	9.2	1.4								756	12.6	0.88	5.5			
	15	93	803	9.2	1.1								855	9.8	0.85	4.4			
	20	70	860	7.5	1.1								974	8.5	0.84	4.1			
	25	56	778	5.5	1.2								920	6.5	0.83	3.9			
	30	47	883	5.5	1.1								947	5.9	0.79	3.2			
	40	35	829	4	1.3								1037	5.0	0.76	2.8			
	50	28	757	3	1.3								959	3.8	0.74	2.6			
	65	22	678	2.2	1.2								801	2.6	0.71	2.3			
	80	18	649	1.8	1.2								758	2.1	0.68	2.1			
	100	14	655	1.5	1.1	699	1.6	0.64	1.8										

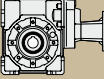
	$n_1 = 1400$		HF										HA						
	i_n	n_2 [min ⁻¹]	T_2 [Nm]	P_1 [kW]	FS'	Input -IEC										T_{2M} [Nm]	P [kW]	Rd	P_{t0}
						HF													
						B5					B14								
H130	30	47	928	5.5	1.3	112 100	90	80	—	1231	7.3	0.83	4.9						
	40	35	1216	5.5	1.0					1238	5.6	0.81	4.4						
	60	23	1279	4	1.1					1375	4.3	0.77	3.6						
	80	18	1194	3	1.2					1472	3.7	0.75	3.3						
	100	14	1111	2.2	1.3					1413	2.8	0.74	3.2						
	120	12	1191	2.2	1.2					1407	2.6	0.68	2.6						
	160	9	1517	2.2	1.0					1517	2.2	0.65	2.4						
	200	7	1269	1.5	1.1					1353	1.6	0.62	2.2						
	260	5	1219	1.1	1.0					1219	1.1	0.58	2.0						
	320	4	1182	0.9	1.0					1182	0.9	0.55	1.8						
	400	3	893	0.55	1.3					1136	0.7	0.51	1.7						

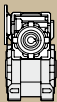
	$n_1 = 1400$		XXC - XXF - KXC										XXA							
	i_n	i_1	i_2	n_2 [min ⁻¹]	T_2 [Nm]	P_1 [kW]	FS'	Input -IEC										T_{2M} [Nm]	P [kW]	Rd
								XXC - KXC					XXF							
								B5/B14		B5			B14							
XX63/130 KX63/130	150	10	15	9.3	1176	1.8	1.2	90	—	90	80	71	90	80	—	1438	2.2	0.64		
	200		20	7.0	1498	1.8	1.2									1831	2.2	0.61		
	300		4.7	1627	1.5	1.2	1890									1.7	0.53			
	450	15	3.1	1655	1.1	1.1	1890									1.3	0.49			
	600	20	2.3	1731	0.9	1.1	1890									0.98	0.47			
	900	30	1.6	1934	0.75	1.0	1890									0.73	0.42			
	1200	40	1.2	1756	0.55	1.1	1890									0.59	0.39			
	1500	50	0.9	2026	0.55	0.9	1890									0.51	0.36			
	1950	65	0.7	1673	0.37	1.1	1890									0.42	0.34			
	2500	50	0.6	2082	0.37	0.9	1920									0.34	0.33			
	3250	65	0.4	1663	0.25	1.2	1920									0.29	0.30			
	4000	80	0.4	1978	0.25	1.0	1920									0.24	0.29			
	5000	100	0.3	2217	0.25	0.9	1920									0.22	0.26			
	10000		100	0.1	3411	0.25	0.4									1276	0.09	0.20		

Lubrificazione

Il riduttore a vite senza fine X130 sono forniti completi di lubrificante sintetico a base PAG con indice di viscosità ISO VG 320.

Si raccomanda di precisare sempre, in fase di ordine la posizione di montaggio desiderata.

Posizioni di montaggio

Lubrication

The X130 worm gearboxes are supplied with synthetic lubricant, PAG base, viscosity index ISO VG320. Required mounting position to be specified when ordering

Mounting position

Schmierung

Schneckengetriebe X130 werden mit synthetischem Schmiermittel auf PAG Basis und Viskosität Index ISO VG320 geliefert.

Bei der Bestellung immer die gewünschte Einbaulage angeben.

Einbaulage

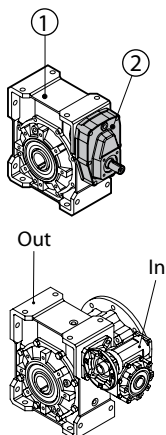
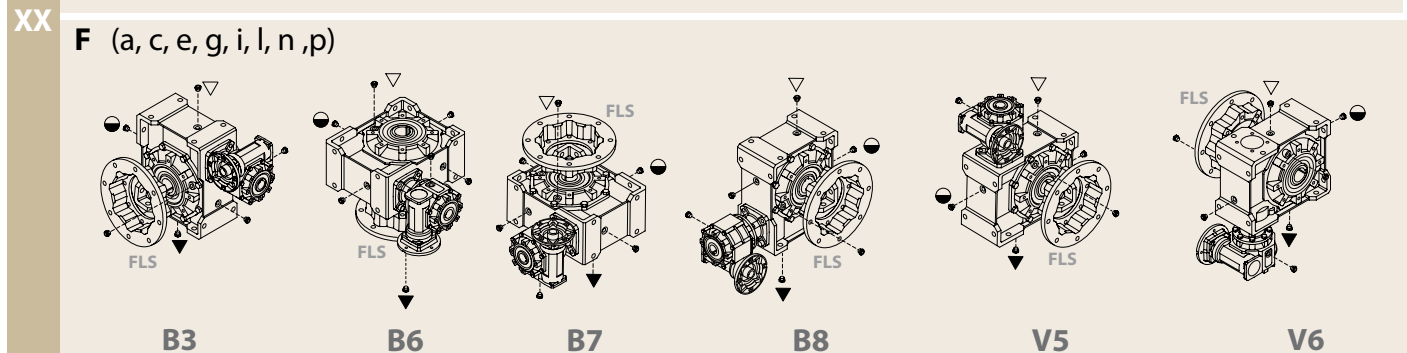
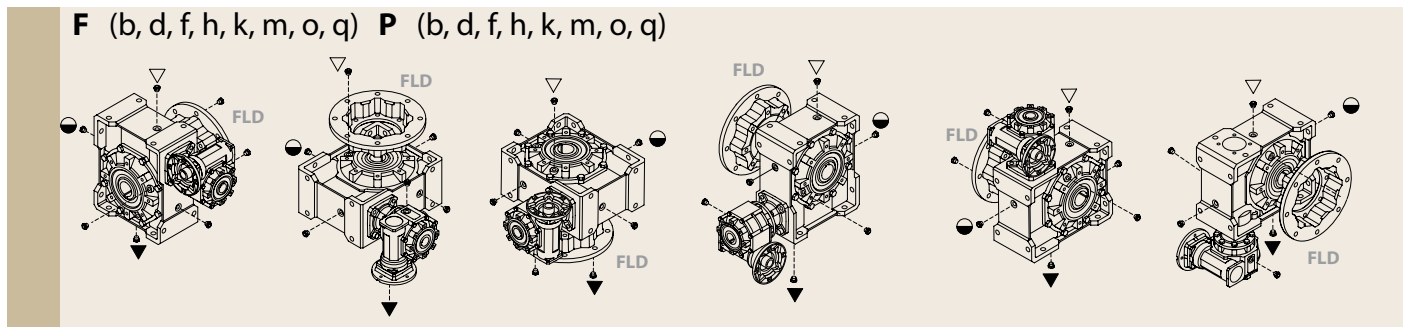
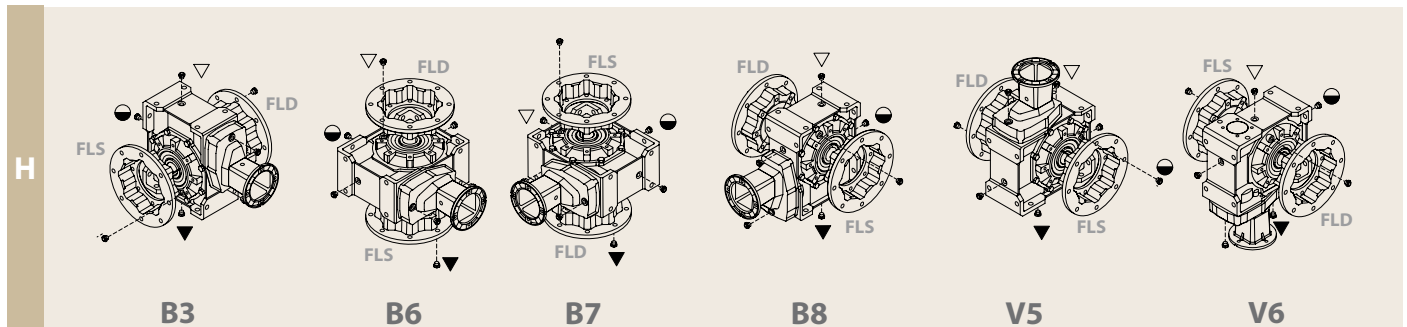
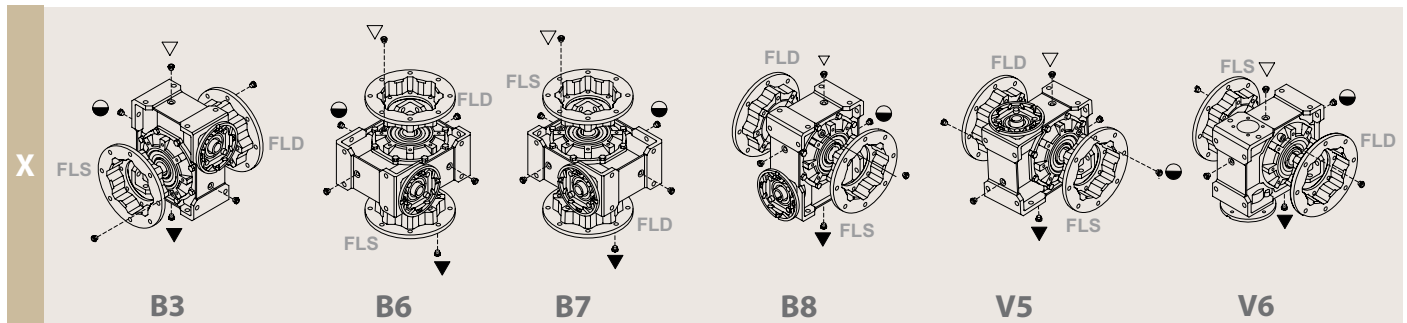

Quantità olio / Oil quantity / Schmiermittelmenge [lt]

		Posizione di montaggio / Mounting position / Einbaulage					
		B3	B6	B7	B8	V5	V6
X		4.2	3.4	3.4	3.2	4.2	3.2
	1	4.2	3.4	3.4	3.2	4.2	3.2
H	2	0.35	0.35	0.35	0.35	0.35	0.35
	In	0.4	0.4	0.4	0.4	0.4	0.4
XX	Out	4.2	3.4	3.4	3.2	4.2	3.2

▽ Carico e sfiato / Filling and breather
Einfüll und Entlüftung

● Livello / Level / Ölstand

▼ Scarico / Drain / Ablass

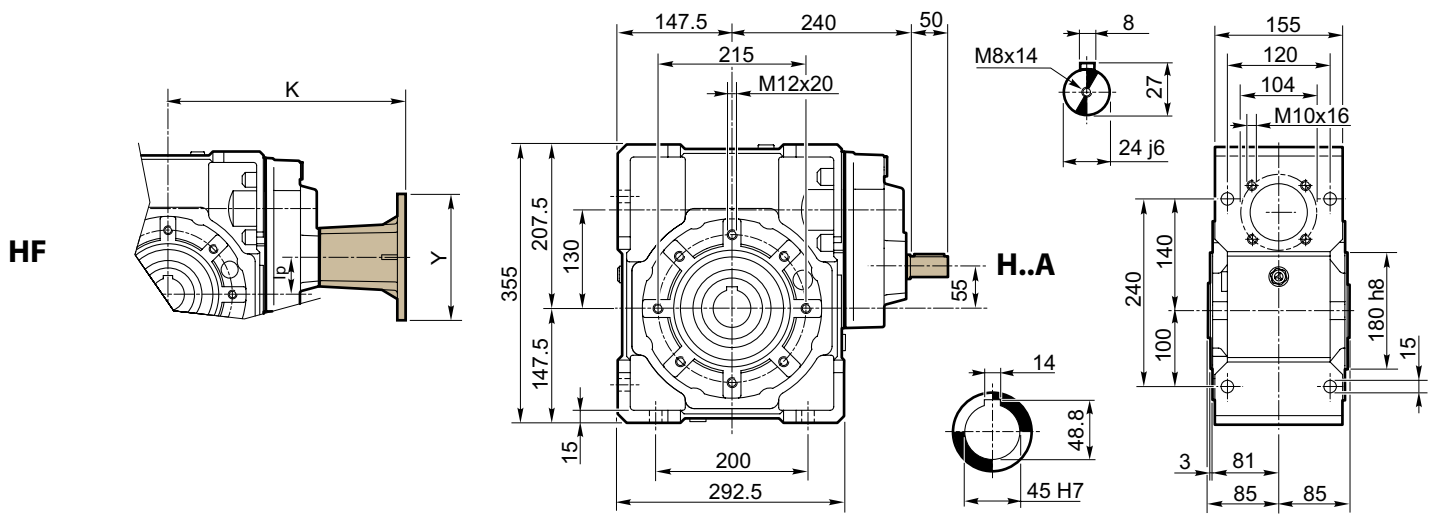
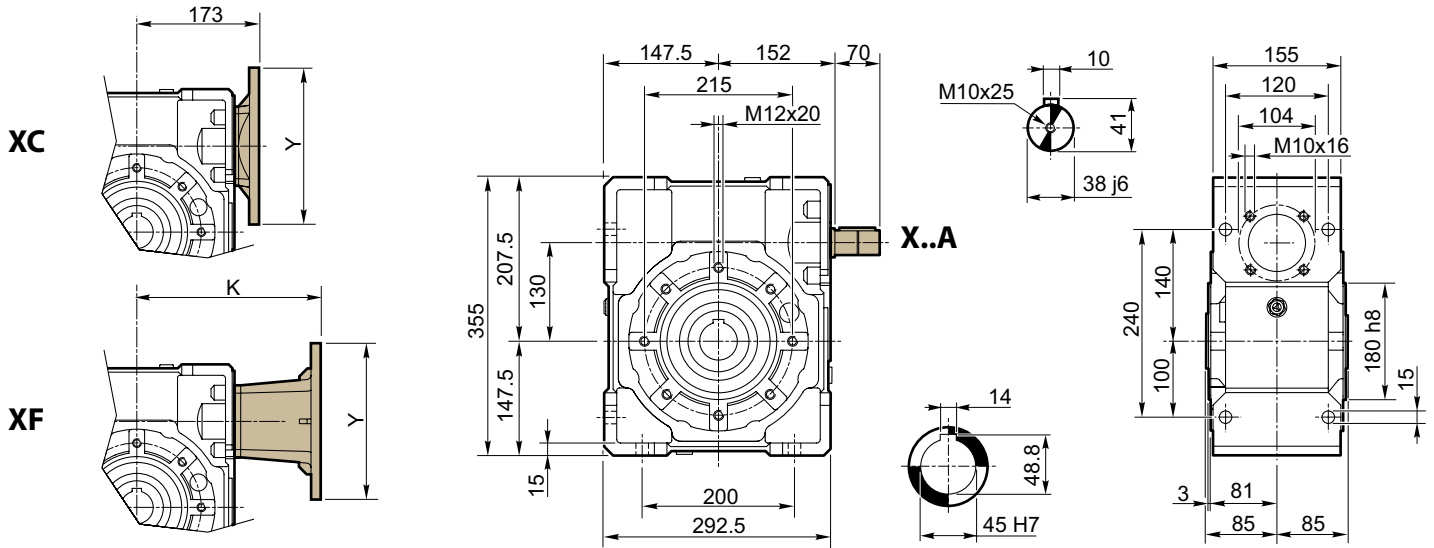

X..C - XX..C - KX..C

X..F - H..F - XX..F

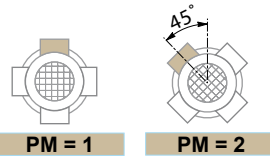
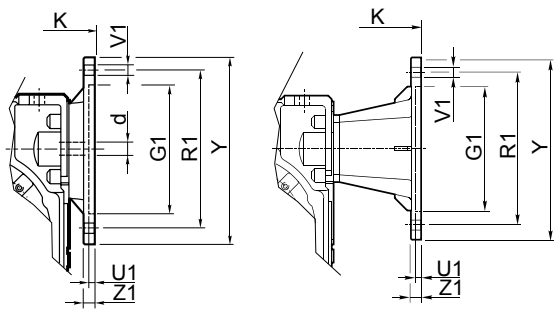

	IEC	d	PM		G1 H7	K	R1	U1	V1	Y	Z1
			1	2							
XC	90 B5	24			130	173	165	5	n°4 ø 11	200	12
	90 B14	24			95	173	115	5	n°4 ø 9	140	12
	100/112 B5	28			180	173	215	5	n°4 ø 14	250	14
	100/112 B14	28			110	173	130	5	n°4 ø 9	160	12
	132 B5	38			230	173	265	5	n°4 ø 14	300	14
	132 B14	38			130	173	165	5	n°4 ø 11	200	12
XF	90 B5	24			130	281	165	4.5	n°4 M10	200	12
	100/112 B5	28			180	289	215	5	n°4 ø 13	250	16
	132 B5	38			230	310	265	5	n°4 ø 13	300	20
HF	80 B5	19			130	345.5	165	4.5	n°4 ø 11	200	12
	90 B5	24			130	345.5	165	4.5	n°4 ø 11	200	12
	100/112 B5	28			180	355.5	215	5	n°4 ø 14	250	14

	IEC	d	PM		G1 H7	K	R1	U1	V1	Y	Z1
			1	2							
XXC	71 B5	14			110	95	130	4.5	n°8 ø 9	160	10
	71 B14	14			70	95	85	3.5	n°4 ø 7	105	10
	80 B5	19			130	95	165	4.5	n°8 ø 11	200	10
	80 B14	19			80	95	100	4	n°4 ø 7	120	10
	90 B5	24			130	95	165	4.5	n°8 ø 11	200	10
	90 B14	24			95	95	115	4	n°8 ø 8.5	140	10
XXF	71 B5	14			110	141.5	130	4.5	n°8 ø 9	160	10
	80 B5	19			130	161.5	165	4.5	n°8 ø 11	200	10
	80 B14	19			80	151.5	100	4	n°8 ø 7	120	10
	90 B5	24			130	161.5	165	4.5	n°8 ø 11	200	10
	90 B14	24			95	161.5	115	4	n°8 ø 9	140	10
	KXC	71 B5	14			110	97	130	4.5	n°8 ø 9	160
71 B14		14			70	97	85	3.5	n°4 ø 7	105	10
80 B5		19			130	97	165	4.5	n°8 ø 11	200	10
80 B14		19			80	97	100	4	n°4 ø 7	120	10
90 B5		24			130	97	165	4.5	n°8 ø 11	200	10
90 B14		24			95	97	115	4	n°8 ø 8.5	140	10

Dimensioni

Dimensions

Abmessungen

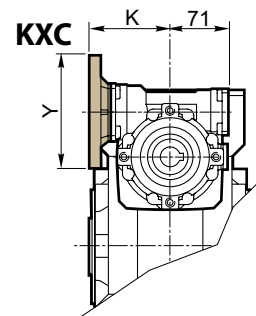
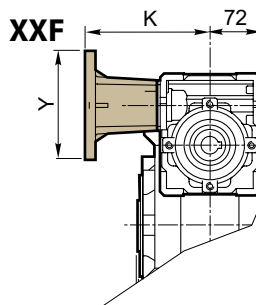
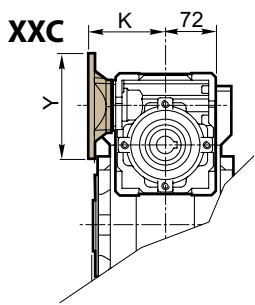
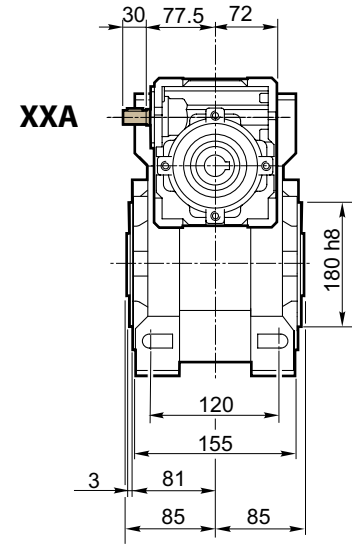
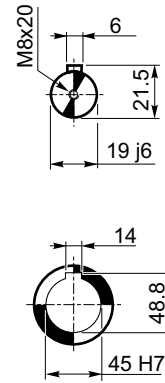
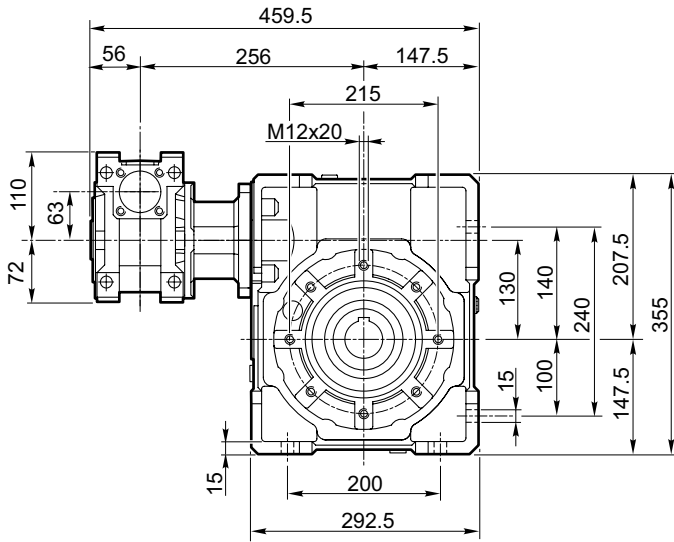

P

F

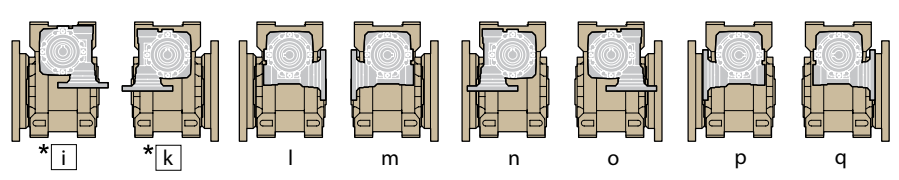
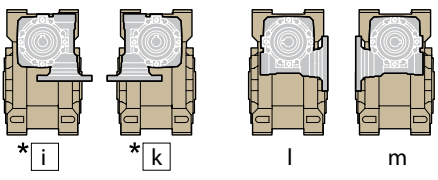
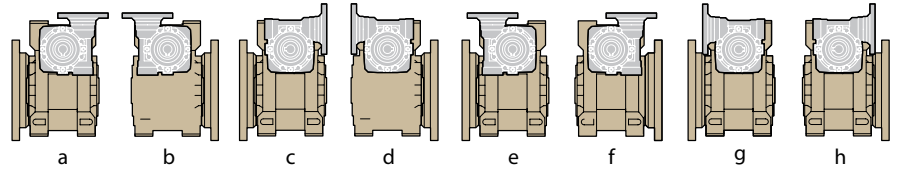
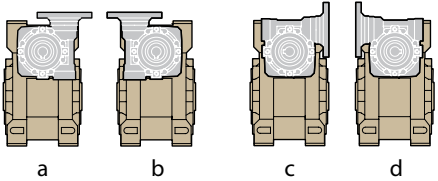

*Versione non realizzabile / Not possible / Nicht lieferbar

Flangia uscita
Output flange
Abtriebsflansch

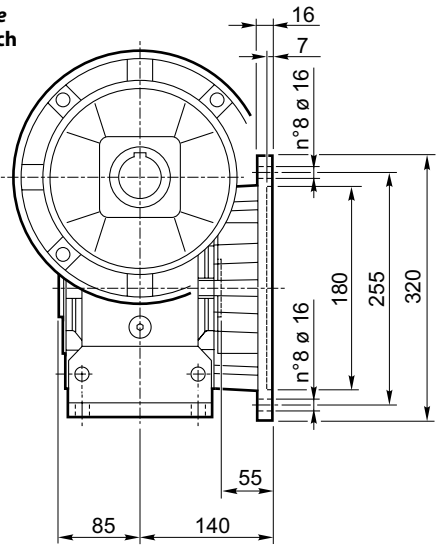

Entrata supplementare
Additional input
Zusatzantrieb

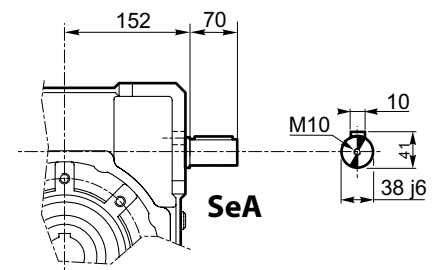

Albero lento semplice
Single output shaft
Standard Abtriebswelle

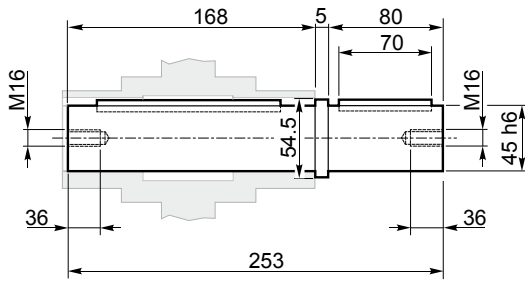

Albero lento doppio
Double output shaft
Doppelte Abtriebswelle

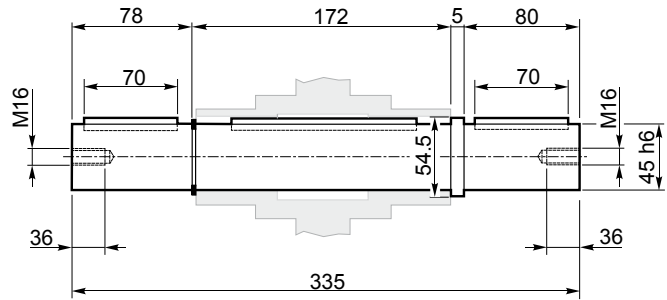

Braccio di reazione
Torque arm
Drehmomentstütze

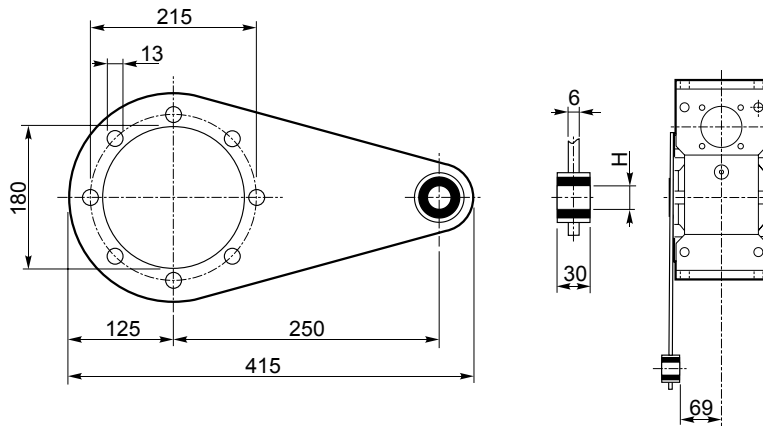

Carichi radiali

Carichi radiali Fr e assiali Fa sugli alberi entrata (1) e uscita (2) [N].

Radial loads

Fr radial loads and Fa axial loads on the input shaft (1) and output shaft (2) [N].

Radialbelastungen

Fr Radialbelastungen und Fa Axialbelastungen auf die Antriebswelle (1) und Abtriebswelle (2) [N].

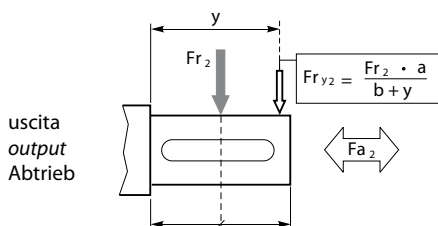
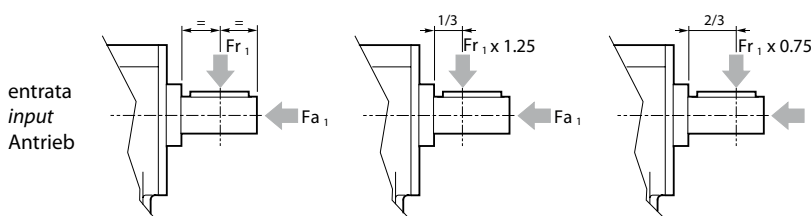

$n_1 = 1400 \text{ min}^{-1}$

n_2 [min ⁻¹]	187	140	93	70	56	47	35	28	22	18	14
Fr_2	5100	5600	6400	7000	7600	8050	8800	9500	10100	11200	12050
Fa_2	1020	1120	1280	1400	1520	1610	1760	1900	2020	2240	2410

$a = 190, b = 145$

$n_1 = 1400 \text{ min}^{-1}$

	X130	H130	XX63/130
Fr_1	1500	1000	480
Fa_1	300	200	96



GAMME DI PRODOTTO
RANGE OF PRODUCTS

Riduttori a vite senza fine / Worm gearboxes
Riduttori a ingranaggi / Helical and bevel helical gearboxes
Riduttori epicicloidali di precisione / Precision planetary gearboxes
Riduttori speciali / Special gearboxes
Variatori di velocità / Mechanical variators

www.tvttradepower.it

Rete commerciale / Sales Network

TVT Motion AB
TRAMEC POLSKA
TRAMEC Getriebe gmbH
TRAMEC FRANCE

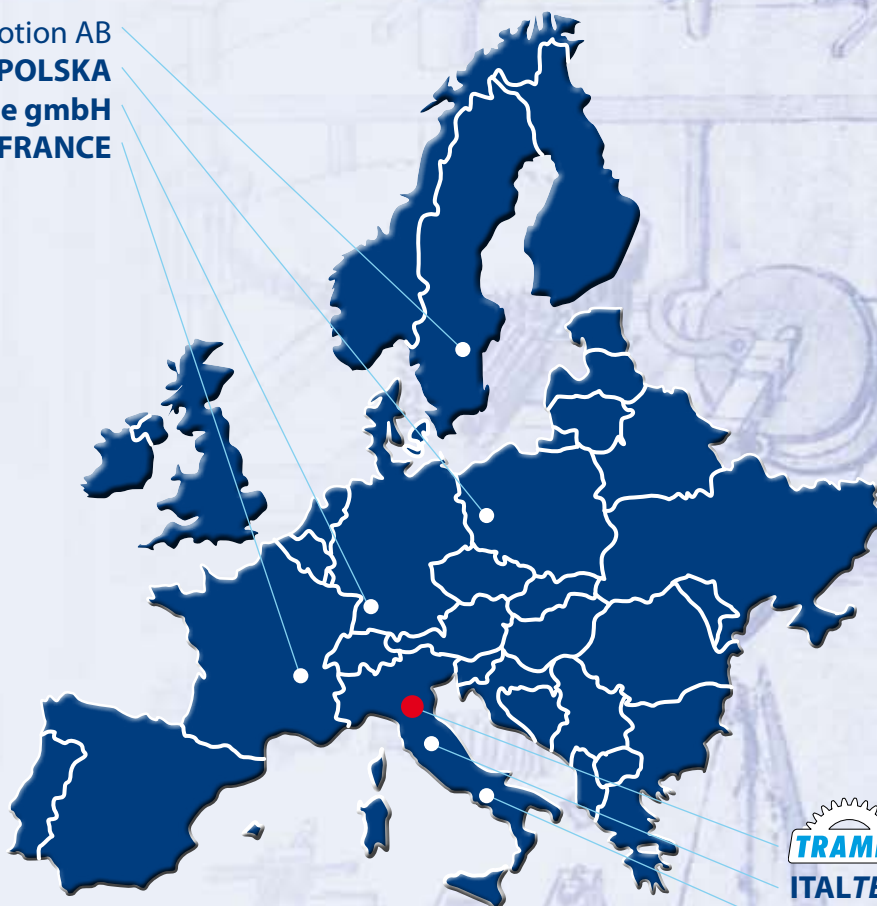

ITALTECH trasmissioni
TRAMEC SUD



TRAMEC S.r.l.

Via Bizzarri 6 - 40012 Calderara di Reno BO - Italy

Tel. +39 051 728935 Fax +39 051 728937

www.tramec.it

tramec@tramec.it